



Product Change Notification

Change Notification #: 117360 - 00
Change Title: Intel® Compute Module HNS2600BPBR,
Intel® Compute Module
HNS2600BPB24R,
Intel® Compute Module HNS2600BPS24R
PCN 117360-00, Product Design,
Design Improvement for Power Cable
Plastic Cover
Date of Publication: December 18, 2019

Key Characteristics of the Change:
Product Design

Forecasted Key Milestones:

Date Customer Must be Ready to Receive Post-Conversion Material:*	January 7, 2020
--	-----------------

* Intel appreciates the customer's desire to receive the latest revision of products. However, Intel manages inventory on a first in first out (FIFO) basis at the MM# level. Subsequently, customer requests for a specific revision of material (below the MM#) will not be supported by Intel.

Description of Change to the Customer:

Intel is implementing an Improvement on Plastic Cover placed upon Intel® Compute Module Power Cables. This design improvement consists of:

- Increase the thickness of hooks by 0.3 mm for both sides
- Reduce 3mm to the rib down the "T"

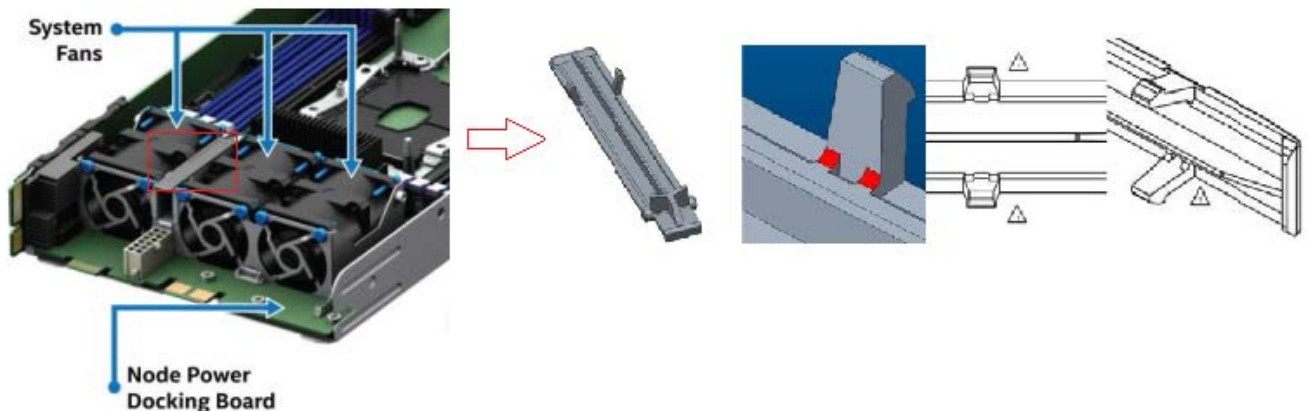

Customer Impact of Change and Recommended Action:

Intel does not expect any other impact to customers from these changes, but encourages customers to understand the change and determine the impact on their applications. For that reason, Intel recommends that the customer perform a standard level of evaluation.

Products Affected / Intel Ordering Codes:

Product Code	MM#	Pre Change TA	Post Change TA
HNS2600BPBR	986116	K36253-003	K36253-004
HNS2600BPB24R	986118	K36256-003	K36256-004
HNS2600BPS24R	986119	K36261-003	K36261-004

PCN Revision History:

Date of Revision:

December 18, 2019

Revision Number:

00

Reason:

Originally Published PCN



Product Change Notification

117360 - 00

INFORMATION IN THIS DOCUMENT IS PROVIDED IN CONNECTION WITH INTEL PRODUCTS. NO LICENSE, EXPRESS OR IMPLIED, BY ESTOPPEL OR OTHERWISE, TO ANY INTELLECTUAL PROPERTY RIGHTS IS GRANTED BY THIS DOCUMENT. EXCEPT AS PROVIDED IN INTEL'S TERMS AND CONDITIONS OF SALE FOR SUCH PRODUCTS, INTEL ASSUMES NO LIABILITY WHATSOEVER AND INTEL DISCLAIMS ANY EXPRESS OR IMPLIED WARRANTY, RELATING TO SALE AND/OR USE OF INTEL PRODUCTS INCLUDING LIABILITY OR WARRANTIES RELATING TO FITNESS FOR A PARTICULAR PURPOSE, MERCHANTABILITY, OR INFRINGEMENT OF ANY PATENT, COPYRIGHT OR OTHER INTELLECTUAL PROPERTY RIGHT.

A "Mission Critical Application" is any application in which failure of the Intel Product could result, directly or indirectly, in personal injury or death. SHOULD YOU PURCHASE OR USE INTEL'S PRODUCTS FOR ANY SUCH MISSION CRITICAL APPLICATION, YOU SHALL INDEMNIFY AND HOLD INTEL AND ITS SUBSIDIARIES, SUBCONTRACTORS AND AFFILIATES, AND THE DIRECTORS, OFFICERS, AND EMPLOYEES OF EACH, HARMLESS AGAINST ALL CLAIMS COSTS, DAMAGES, AND EXPENSES AND REASONABLE ATTORNEYS' FEES ARISING OUT OF, DIRECTLY OR INDIRECTLY, ANY CLAIM OF PRODUCT LIABILITY, PERSONAL INJURY, OR DEATH ARISING IN ANY WAY OUT OF SUCH MISSION CRITICAL APPLICATION, WHETHER OR NOT INTEL OR ITS SUBCONTRACTOR WAS NEGLIGENT IN THE DESIGN, MANUFACTURE, OR WARNING OF THE INTEL PRODUCT OR ANY OF ITS PARTS.

Intel may make changes to specifications and product descriptions at any time, without notice. Designers must not rely on the absence or characteristics of any features or instructions marked "reserved" or "undefined". Intel reserves these for future definition and shall have no responsibility whatsoever for conflicts or incompatibilities arising from future changes to them. The information here is subject to change without notice. Do not finalize a design with this information.

The products described in this document may contain design defects or errors known as errata which may cause the product to deviate from published specifications. Current characterized errata are available on request.

Should you have any issues with the timeline or content of this change, please contact the Intel Representative(s) for your geographic location listed below. No response from customers will be deemed as acceptance of the change and the change will be implemented pursuant to the key milestones set forth in this attached PCN.

Americas Contact: asmo.pcn@intel.com

Asia Pacific/PRC Contact: apacgccb@intel.com

Europe Email: eccb@intel.com

Japan Email: jccb.ijkk@intel.com

Copyright © Intel Corporation 2019. Other names and brands may be claimed as the property of others.

3D XPoint, ACEX, Altera, APEX, AnyWAN, Arria, Avalon, Axxia, BlueMoon, BunnyPeople, Celeron, Centrino, Cilk, CONVERGATE, Cyclone, Docea, eASIC, easicopy, Enpirion, Flexpipe, Hyperflex, Intel, the Intel logo, Intel Adaptix, Intel Agilix, Intel Atom, Intel CoFluent, Intel Core, Intel. Experience What's Inside, the Intel. Experience What's Inside logo, Intel Falcon, Intel Inside, the Intel Inside logo, Intel Nervana, Intel Optane, Intel RealSense, Intel Shooting Star, Intel Sirius, Intel SpeedStep, Intel Unite, Intel vPro, Intel Xeon Phi, Iris, Itanium, MAX, Movidius, Myriad, neon, Nios, OpenVINO, the OpenVINO logo, Pentium, Puma, Quark, Quartus, SICOFI, Simics, SMARTi, SoftSilicon, Sound Mark, StarPro, Stratix, the Stratix logo, Stay With It, the Engineering Stay With It logo, StreamSight, Tarari, The Journey Inside, Thunderbolt, the Thunderbolt logo, Transcende, Ultrabook, VTune, Xeon, X-GOLD, XMM, X-PMU and XPOSYS are trademarks of Intel Corporation or its subsidiaries in the U.S. and/or other countries.

Microsoft, Windows, and the Windows logo are trademarks, or registered trademarks of Microsoft Corporation in the United States and/or other countries. Java is a registered trademark of Oracle and/or its affiliates. Bluetooth is a trademark owned by its proprietor and used by Intel Corporation under license. Intel Corporation uses the Palm OS® Ready mark

under license from Palm, Inc. OpenCL and the OpenCL logo are trademarks of Apple Inc. used by permission by Khronos. Learn how to use Intel Trademarks and Brands correctly at <http://www.intel.com/intel/legal/tmusage2.htm>.