



# Product Change Notification

**Change Notification #:** 116436 - 00  
**Change Title:** Intel® Spare Drive Bays & Carrier Options FXX35HSCAR2, PCN 116436-00, Product Design, Update 3.5" tool less carriers design to improve hard to push out (stuck) in S2600WF Family  
**Date of Publication:** August 16, 2018

## Key Characteristics of the Change:

Product Design

## Forecasted Key Milestones:

<b>Date Customer Must be Ready to Receive Post-Conversion Material*:</b>	August 31, 2018
--	-----------------

\* Intel appreciates the customer's desire to receive the latest revision of products. However, Intel manages inventory on a first in first out (FIFO) basis at the MM# level. Subsequently, customer requests for a specific revision of material (below the MM#) will not be supported by Intel.

## Description of Change to the Customer:

Intel is updating the Intel® Spare Drive Bays & Carrier Options FXX35HSCAR2 to improve the mobility of the carrier when removing from the chassis, by adding a groove on the carrier frame to avoid hook touching edge (See below images).

All new components perform the same operation with improvements on their design.

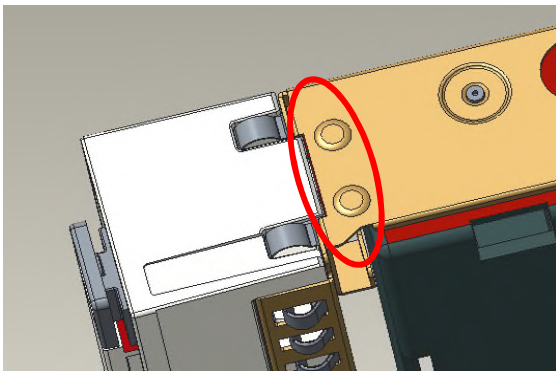

Figure 1: Previous Shape

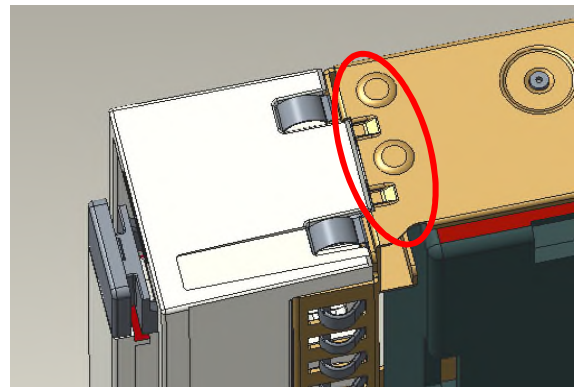

Figure 2: New shape with groove

## Customer Impact of Change and Recommended Action:

Intel does not expect any impact to customers from these changes, but encourages customers to understand the change and determine the impact on their applications.

## Products Affected / Intel Ordering Codes:

Product Code	MM#	Pre Change TA	Post Change TA
FXX35HSCAR2	958245	J37328-001	J37328-002

## PCN Revision History:

**Date of Revision:**

August 16, 2018

**Revision Number:**

00

**Reason:**

Originally Published PCN



# Product Change Notification

## 116436 - 00

**INFORMATION IN THIS DOCUMENT IS PROVIDED IN CONNECTION WITH INTEL PRODUCTS. NO LICENSE, EXPRESS OR IMPLIED, BY ESTOPPEL OR OTHERWISE, TO ANY INTELLECTUAL PROPERTY RIGHTS IS GRANTED BY THIS DOCUMENT. EXCEPT AS PROVIDED IN INTEL'S TERMS AND CONDITIONS OF SALE FOR SUCH PRODUCTS, INTEL ASSUMES NO LIABILITY WHATSOEVER AND INTEL DISCLAIMS ANY EXPRESS OR IMPLIED WARRANTY, RELATING TO SALE AND/OR USE OF INTEL PRODUCTS INCLUDING LIABILITY OR WARRANTIES RELATING TO FITNESS FOR A PARTICULAR PURPOSE, MERCHANTABILITY, OR INFRINGEMENT OF ANY PATENT, COPYRIGHT OR OTHER INTELLECTUAL PROPERTY RIGHT.**

A "Mission Critical Application" is any application in which failure of the Intel Product could result, directly or indirectly, in personal injury or death. SHOULD YOU PURCHASE OR USE INTEL'S PRODUCTS FOR ANY SUCH MISSION CRITICAL APPLICATION, YOU SHALL INDEMNIFY AND HOLD INTEL AND ITS SUBSIDIARIES, SUBCONTRACTORS AND AFFILIATES, AND THE DIRECTORS, OFFICERS, AND EMPLOYEES OF EACH, HARMLESS AGAINST ALL CLAIMS COSTS, DAMAGES, AND EXPENSES AND REASONABLE ATTORNEYS' FEES ARISING OUT OF, DIRECTLY OR INDIRECTLY, ANY CLAIM OF PRODUCT LIABILITY, PERSONAL INJURY, OR DEATH ARISING IN ANY WAY OUT OF SUCH MISSION CRITICAL APPLICATION, WHETHER OR NOT INTEL OR ITS SUBCONTRACTOR WAS NEGLIGENT IN THE DESIGN, MANUFACTURE, OR WARNING OF THE INTEL PRODUCT OR ANY OF ITS PARTS.

Intel may make changes to specifications and product descriptions at any time, without notice. Designers must not rely on the absence or characteristics of any features or instructions marked "reserved" or "undefined". Intel reserves these for future definition and shall have no responsibility whatsoever for conflicts or incompatibilities arising from future changes to them. The information here is subject to change without notice. Do not finalize a design with this information.

The products described in this document may contain design defects or errors known as errata which may cause the product to deviate from published specifications. Current characterized errata are available on request.

**Should you have any issues with the timeline or content of this change, please contact the Intel Representative(s) for your geographic location listed below. No response from customers will be deemed as acceptance of the change and the change will be implemented pursuant to the key milestones set forth in this attached PCN.**

**Americas Contact:** [asmo.pcn@intel.com](mailto:asmo.pcn@intel.com)

**Asia Pacific/PRC Contact:** [apagccb@intel.com](mailto:apagccb@intel.com)

**Europe Email:** [eccb@intel.com](mailto:eccb@intel.com)

**Japan Email:** [jccb.ijkk@intel.com](mailto:jccb.ijkk@intel.com)

Copyright © Intel Corporation 2018. Other names and brands may be claimed as the property of others.

3D XPoint, Axxia, Basis, Basis Peak, BlueMoon, BunnyPeople, Celeron, Centrino, Cilk, Curie, Flexpipe, Intel, the Intel logo, Intel Atom, Intel CoFluent, Intel Core, Intel. Experience What's Inside, the Intel. Experience What's Inside logo, Intel Inside, the Intel Inside logo, Intel Insider, Intel Joule, Intel RealSense, Intel SingleDriver, Intel SpeedStep, Intel Unite, Intel vPro, Intel Xeon Phi, Intel XScale, InTru, the InTru logo, the InTru Inside logo, InTru soundmark, Iris, Itanium, MCS, MMX, Optane, Ostro, Pali, Pentium, picoArray, Picochip, picoXcell, Puma, Quark, SMARTi, Soletta, Sound Mark, StarPro, Stay With It, the Engineering Stay With It logo, StreamSight, Tarari, The Journey Inside, Thunderbolt, the Thunderbolt logo, Transcede, True Key, Ultrabook, VTune, Xeon, X-GOLD, XMM, X-PMU and XPOSYS are trademarks of Intel Corporation or its subsidiaries in the U.S. and/or other countries.

Microsoft, Windows, and the Windows logo are trademarks, or registered trademarks of Microsoft Corporation in the United States and/or other countries. Java is a registered trademark of Oracle and/or its affiliates. Bluetooth is a trademark owned by its proprietor and used by Intel Corporation under license. Intel Corporation uses the Palm OS\* Ready mark under license from Palm, Inc. OpenCL and the OpenCL logo are trademarks of Apple Inc. used by permission by Khronos. Learn how to use Intel Trademarks and Brands correctly at <http://www.intel.com/intel/legal/tmusage2.htm>.